

INSTRUCTIONS FOR USE

Sara Stedy Sara Stedy Compact



WARNING

To avoid injury, always read this Instructions for Use and accompanied documents before using the product.



Mandatory to read the Instructions for Use

Design Policy and Copyright

® and ™ are trademarks belonging to the Arjo group of companies.

© Arjo 2022.

As our policy is one of continuous improvement, we reserve the right to modify designs without prior notice.

The content of this publication may not be copied either whole or in part without the consent of Arjo.

Table of Contents

General Information	5
Foreword	5
Service and Support	5
Manufacturer Information	6
Definitions Used in this Manual	6
Intended Use	6
Patient/Resident Assessment	7
Installation Requirements	7
Expected Service Life	7
Sara Steady Directions	7
Conditions	8
Equipment Identification	8
Verifying the Package Contents	8
Policy on Number of Staff Members Required for Patient Transfer	8
How to Use this Manual	8
Symbols Used	9
Safety Instructions	10
General Instructions	10
Safe Working Load	10
Important Safety Directions	10
Homecare Environment Considerations	11
Equipment Warning Labels	11
Part Designation	12
Slings	13
Compatible Slings	13
How to Use the Sara Steady	14
Using the Sling Attachment Lugs	14
Pivoting the Cushions	14
Opening and Closing the Legs	15
Applying and Releasing the Brakes on the Rear Castors	15
Approaching the Patient	16
Before Transferring the Patient	16
Transferring the Patient	17
Transferring the Patient from a Chair	17
Transferring the Patient to a Chair	18
Transferring the Patient from a Wheelchair	19
Transferring the Patient to a Wheelchair	20
Transferring the Patient from a Bed	21
Transferring the Patient to a Bed	22
Transferring the Patient from a Toilet	23
Transferring the Patient to a Toilet	24
Transferring the Patient at the Toilet	24
Back Support Strap	25
Using the Back Support Strap	25
Kneepad cushion (optional)	26
Installing the kneepad cushion	26
Removal of the kneepad cushion	26

Table of Contents

- Care and Maintenance27**
 - Preventive Maintenance Schedule27
 - User Inspections27
 - Cleaning and Disinfection 29
 - Sling Inspection and Care29
 - Annual Inspection30
- Troubleshooting31**
- Labels on the Sara Stedy32**
- Technical Specifications33**
 - Lift Dimensions Sara Stedy34
 - Lift Dimensions Sara Stedy Compact35

General Information

Thank you for purchasing the Sara Stedy floor lift from Arjo.

Your Sara Stedy is part of a series of quality products designed specially for hospitals, nursing homes and other health care uses.

We are dedicated to serving your needs and providing the best products available along with training that will bring your staff maximum benefit from every Arjo product.

Please read this manual thoroughly, and contact us if you have any questions about the operation or maintenance of your Arjo equipment.

If a serious incident occurs in relation to this medical device, affecting the user, or the patient then the user or patient should report the serious incident to the medical device manufacturer or the distributor. In the European Union, the user should also report the serious incident to the Competent Authority in the member state where they are located.

Foreword

NOTE: Sara Stedy refers to both Sara Stedy and Sara Stedy Compact in this manual.

Please read this manual in its entirety before using your Sara Stedy. The information in this manual is crucial to the proper operation and maintenance of the equipment, and will help protect your product as well as ensure that the equipment performs to your satisfaction. Some of the information in this manual is important for your safety and must be read and understood to help prevent injuries.

WARNING: To avoid injuries that can be attributed to the use of inadequate parts, Arjo strongly advises and warns that only Arjo designated parts should be used on equipment and other appliances supplied by Arjo. Unauthorised modifications on any Arjo equipment may affect its safety. Arjo will not be held responsible for any accidents, incidents or lack of performance that occur as a result of any unauthorised modification to its products.

Tested according to standards: ISO10535:2006

Service and Support

A service routine must be performed on your Sara Stedy by qualified service personnel. This will ensure the safety and good functioning of your product. See section called “Care and Maintenance” in this manual.

General Information

If you require further information, please contact your representative which can offer comprehensive support and service programs to maximize the long-term reliability, safety and value of the product. Contact your local representative for replacement parts.

Additional copies of this manual can be ordered from your local Arjo representative. When ordering, include the *Instructions for Use* product number (see front page) and equipment identification number.

Manufacturer Information

This product has been manufactured by:

ArjoHuntleigh AB
Hans Michelsengatan 10
211 20 Malmö,
SWEDEN

Definitions Used in this Manual

WARNING:

Means: Failure to understand and follow these instructions may result in injury to yourself and others.

CAUTION:

Means: Failure to follow these instructions may cause damage to the product.

NOTE:

Means: This is important information regarding the correct use of the equipment.

Intended Use

Sara Stedy is a mobile active lift with a safe working load (SWL) of 182 kg (400lb). It is intended to assist caregivers in hospitals, long-term care, nursing homes and home care environments, including private homes.

WARNING: To avoid injury, transfers must only be performed on flat, non-sloping surfaces/floors to prevent the Sara Stedy from tipping over.

Sara Stedy is manufactured to a very high standard and has been designed to quickly and easily transport or transfer patients from one sitting position to another. It is not intended for long periods of sitting or transfer.

Sara Stedy is intended to transfer a patient to/from a chair, wheelchair, a bed and a toilet.

Sara Stedy may also be used as supportive aid when elevating a patient for the purposes of changing wound dressings, incontinence pads or for personal cleansing.

Sara Stedy is also suitable for rehabilitation exercises.

Any references to the “patient” in this document apply equally to a resident at home or in a long term care facility and refer to the person transferred.

Sara Stedy must be used by appropriately trained caregivers with adequate knowledge of the care environment, its common practices and procedures, and in accordance with the guidelines in the Instructions for Use.

Sara Stedy should only be used for the purpose specified in this Instructions for Use. Any other use is prohibited.

General Information

Patient/Resident Assessment

It is recommended that facilities establish regular assessment routines to make sure that caregivers are assessing each patient/residents prior to use.

Before use, the caregiver should always consider the patient's/resident's medical condition as well as physical and mental capabilities.

In addition, the patient/resident must:

- have a maximum weight of 182 kg (400 lb)
- have the ability to stand unaided or stand with minimal assistance
- be able to sit on the edge of the bed
- have a height within the range of
 - 1,49m (4'11") and 1,93m (6'4") for Sara Stedy (NTB2000)
 - 1,38m (4'6") and 1,72m (5'8") for Sara Stedy Compact (NTB3000)

WARNING: To avoid injury, a full clinical assessment of the patient's condition and suitability must be carried out by qualified personnel before attempting to use Sara Stedy.

Installation Requirements

No installation is required.

Expected Service Life

The expected service life of Sara Stedy is the maximum period of useful life.

The expected service life of this equipment is ten (10) years from the date of manufacture subject to preventive maintenance being carried out in accordance with the instructions for care and maintenance found in the Instructions for Use.

Actual service life may vary depending on the frequency of use and conditions.

For the expected service life of the slings, please refer to the active slings IFU.

Sara Stedy Directions

References to left or right in these instructions are as viewed from the caregiver's pushing position, standing at the rear of the Sara Stedy, facing forward.

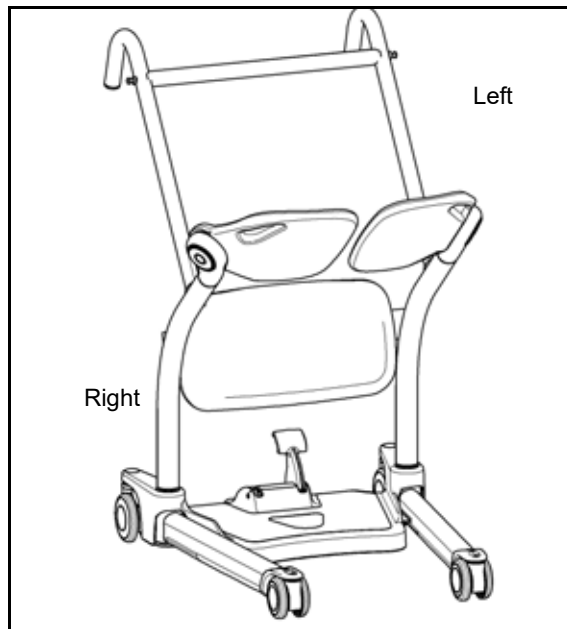

Fig. 1

General Information

Conditions

The unit is cared for and serviced in accordance with the IFU and is maintained to the minimum requirements, published in the “Preventive Maintenance Schedule” section of this manual.

The servicing and product care, in accordance with Arjo requirements, must begin on first use of the unit by the customer. The equipment must be used for its intended purpose only and should be operated within the published limitations. Only Arjo designated spare parts can be used.

WARNING: To avoid patient falling or part malfunction, do not exceed the expected service life, as the manufacturer cannot ensure full safety for a raising and transfer aid.

Equipment Identification

The unit's identification number (specification, model, serial number) appears on a nameplate affixed on the side of the frame.

Verifying the Package Contents

Upon receipt of the equipment, verify it against the packing list to ensure it is complete and inspect the equipment for possible damage due to shipping. If there is any damage, notify the carrier immediately to file a claim. Provide complete information concerning damage claims or shipping errors to your local Arjo representative. Include all equipment identification numbers and group part numbers (if any) as described above along with a full description of damaged parts.

Policy on Number of Staff Members Required for Patient Transfer

Arjo's passive and active series of lifts are designed for safe usage with one caregiver. There are circumstances, such as combativeness, obesity, contractures, etc., of the patient that may dictate the need for a two-person transfer. It is the responsibility of each

facility or medical professional to determine if a one or two-person transfer is more appropriate, based on the task, patient load, environment, capability, and skill level of the staff members.

How to Use this Manual









Information in this IFU is necessary to perform the operation and maintenance of the equipment. It will help to protect your product and make sure that the equipment performs to your satisfaction. The information in this IFU is important for the safety of both patient and caregiver and must be read and understood to help prevent possible injury.

If anything is not completely understood, please contact your local Arjo representative for more details.

Keep this manual with the lift and refer to it as required. Make sure that all operators are regularly trained in the use of the equipment according to the information found therein.

General Information

Symbols Used

Symbol	Key to symbols
	This symbol is accompanied by a date to indicate the date of manufacture and by the address of the manufacturer.
	CE marking indicating conformity with European Community harmonised legislation.
	This symbol is accompanied by the manufacturer's catalogue number.
	This symbol is accompanied by the manufacturer's serial number.
	This symbol refers to the <i>Instructions for Use</i> .
	This symbol indicates a risk of pinching.
	Indicates that the product is a Medical Device according to the EU Medical Device Regulation 2017/745.
	Unique Device Identifier

UK SYMBOL EXPLANATION

This section is only applicable to United Kingdom (UK) market when UK marking is applied to the Arjo medical device labelling.



UK marking indicating conformity with UK Medical Devices Regulations 2002(SI 2002 No 618, as amended)

UK Responsible Person & UK Importer:

Arjo (UK) Ltd, ArjoHuntleigh House, Houghton Regis. LU5 5XF

Is the appointed UK Responsible Person as defined in UK Medical Devices Regulations 2002 (SI 2002 No 618, as amended).

For Northern Ireland (NI) CE marking will still apply until further amendment to applicable regulations.

Fig. 2

Safety Instructions

The equipment must be used in accordance with these safety instructions.

Anyone using the equipment must also have read and understood the instructions in this manual.

If there is anything you are not sure about, contact your local Arjo representative.

General Instructions

Keep these safety instructions with the unit at all times.

Read the *Instructions for Use* before installing, operating, or servicing this equipment.

Sara Stedy should only be used for the purposes specified in this IFU. Any other use is prohibited.

WARNING: If a sling is used, to avoid injury, always position it around the patient according to the instructions in this IFU.

Safe Working Load

The Sara Stedy has been designed with a capacity of 182 kg (400 lb).

WARNING: To avoid falling, make sure that the patient's weight is lower than the safe working load for all products or accessories being used.

Important Safety Directions

- Always carry out the recommended daily maintenance before using the lift.
- Always maneuver the Sara Stedy by using the handles. Do not push on the legs.
- Ensure that you are prepared before attempting to transfer a patient.

WARNING: To avoid the device from tipping and the patient falling, do not use the equipment on surfaces not easily rolled over such as steps, thresholds and sidewalks.

- Do not push the lift at a speed which exceeds a slow walking pace (3 km/hour or 0.8 meter/second).

Safety Instructions

- An assessment of the suitability for transfer of a patient who is connected to electrodes, catheters or other medical devices must be conducted by qualified personnel before performing the transfer.
- This mobile patient lift must be used by a caregiver trained with these instructions and qualified to work with the patient to be transferred and should never be used by patients on their own. Failure to comply may result in a patient fall.
- Avoid any impact during transfer. Impacts can damage and weaken the frame of the Sara Steady. This could cause the lift to tip over or the patient to fall.
- Ensure the sling is intended to be used for this lift and can take the weight of the patient.
- Ensure the sling is not damaged, torn or frayed.
- Ensure the sling straps are in good condition and properly fastened.
- Replace any precautionary or instruction labels that cannot be easily read.

WARNING: To avoid any Sara Steady instability or serious injuries during transfer, always make sure that the brakes are applied on the Sara Steady when attempting a transfer.

WARNING: To avoid falling, make sure both seat cushions are pivoted down before the patient is seated.

WARNING: To avoid falling, make sure that the patient is positioned correctly during transfer.

WARNING: To avoid injury, a full clinical assessment of the patient's condition and suitability must be carried out by qualified personnel before attempting to use Sara Steady for rehabilitation activities.

WARNING: To avoid serious injury, the patient must limit extended reaching or leaning movements while in the Sara Steady.

WARNING: To prevent falls, if the patient will be standing in the device for an extended period, always make sure that both seat halves are placed in the seating position.

NOTE: During rehabilitation activities, the caregiver must regularly assess the patient's strength, as the patient will be required to stand so that the seat halves can be raised and the patient can exit.

Homecare Environment Considerations

WARNING: To avoid serious injuries, make sure that the Sara Steady is never operated by children.

CAUTION: The Sara Steady should be rigorously cleaned after being exposed to an animal. Pet hair trapped inside the device can reduce the product's performance.

WARNING: This product contains small parts that might present a severe danger to children if swallowed or inhaled.

Equipment Warning Labels

Inspect all precautionary labels on the equipment. Order and replace all labels that cannot be easily read.

Part Designation

Sara Steady

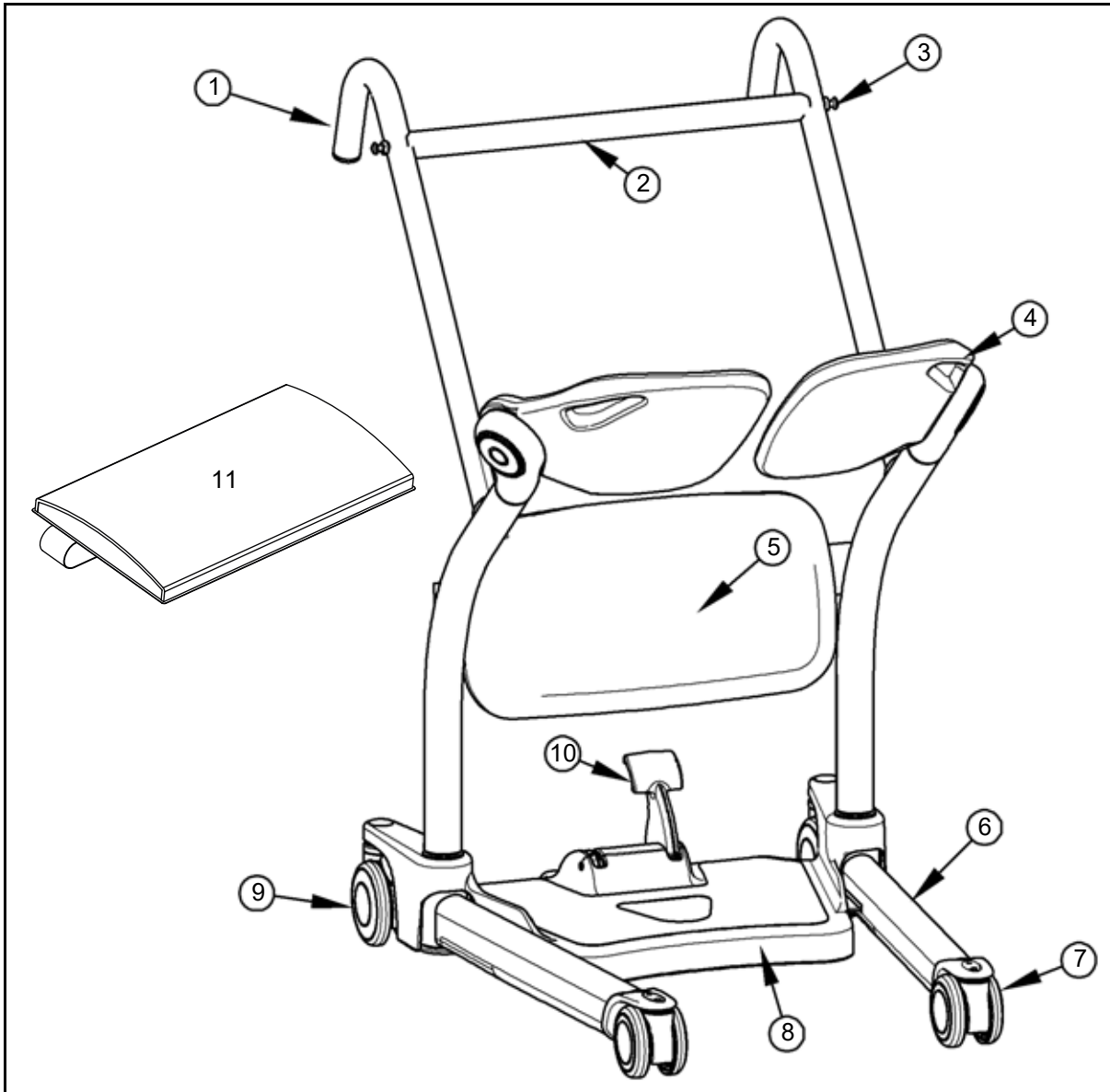

Fig. 3

Legend

- | | |
|---|---------------------------------|
| 1) Manoeuvring handles | 7) Front castor |
| 2) Crossbar / Handle bar | 8) Footboard / Base |
| 3) Sling attachment lugs | 9) Rear castor with brake |
| 4) Pivoting seat halves / pads / cushions | 10) Leg pivot footlever / Pedal |
| 5) Kneepad | 11) Kneepad cushion |
| 6) Leg | |

Slings

Compatible Slings

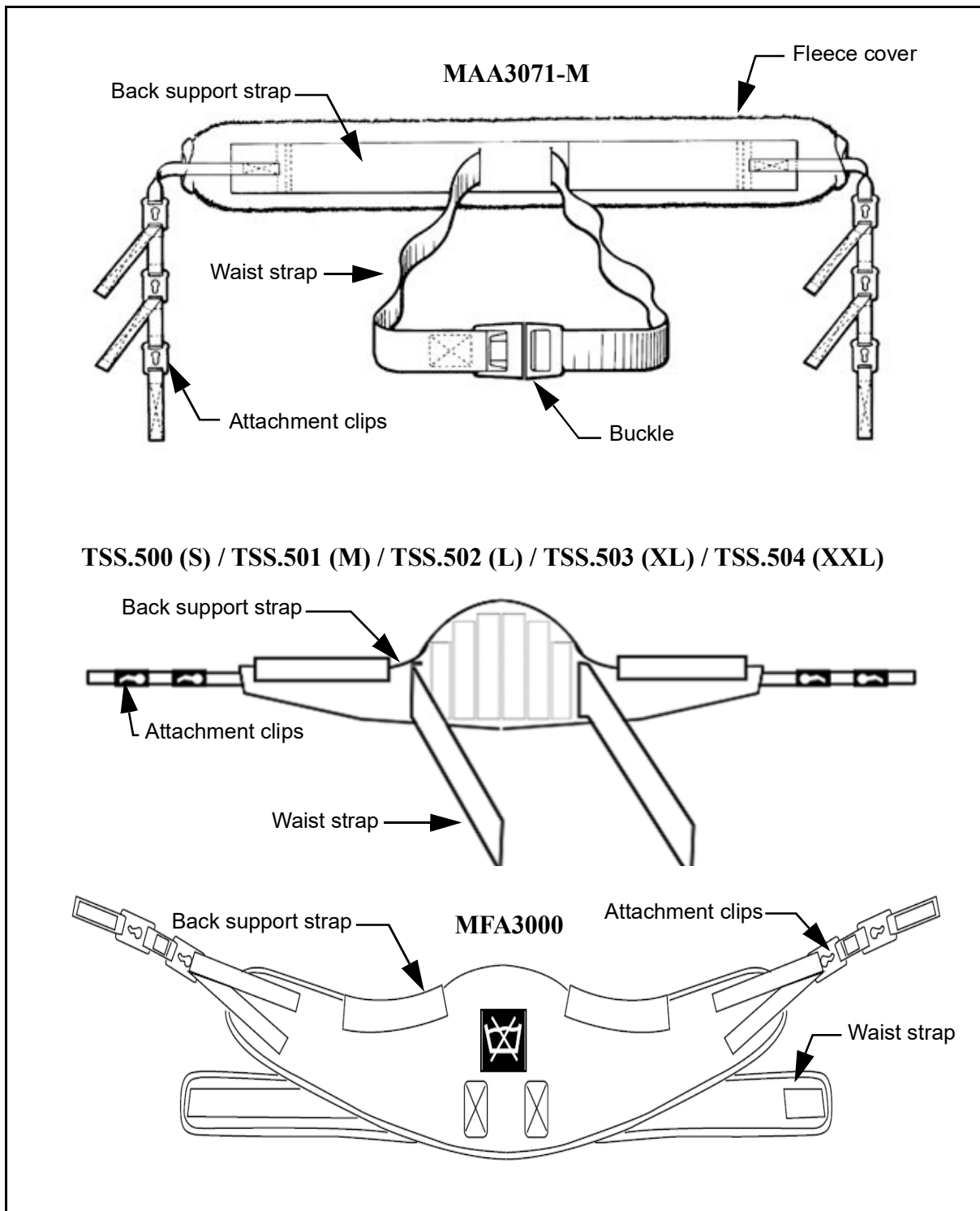

Fig. 4

For more information about sling use, please refer to the documentation that comes with your sling.

How to Use the Sara Steady

NOTE: The use of sling is optional and dependent on patient assessment.

Using the Sling Attachment Lugs

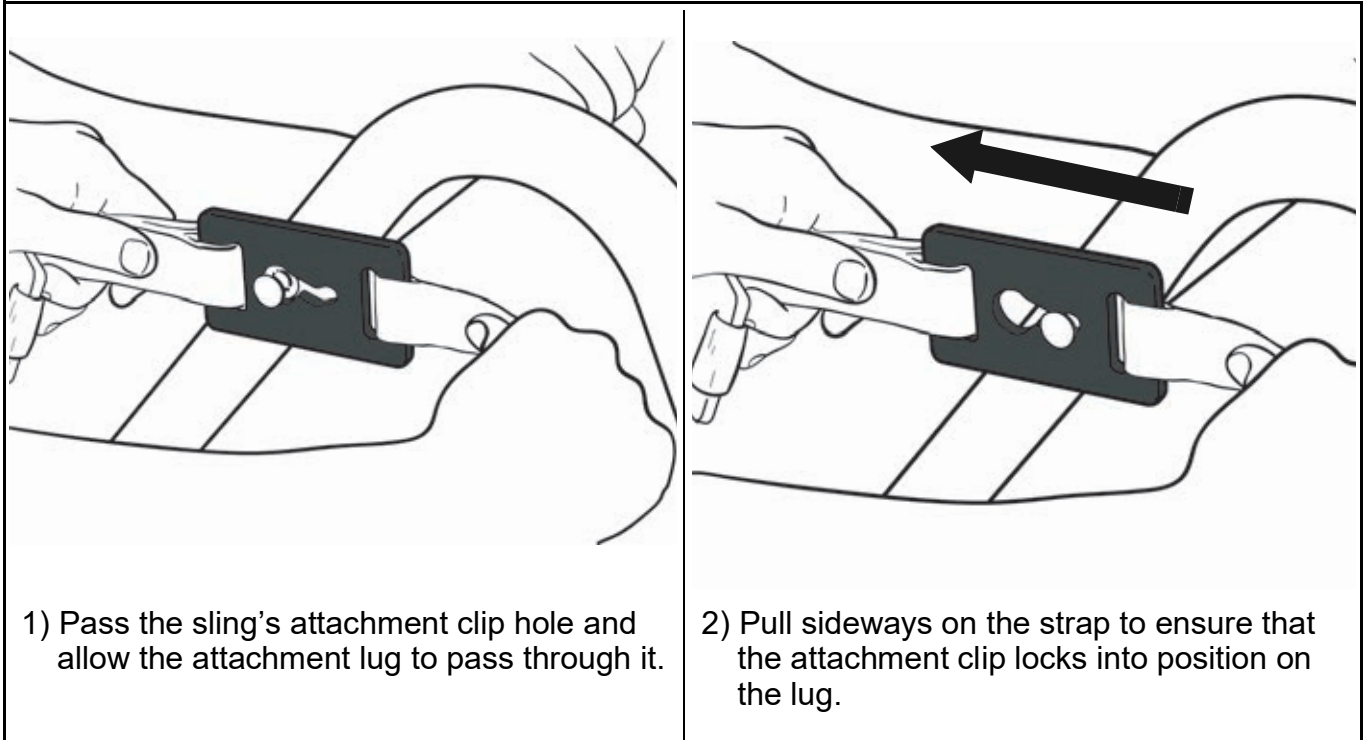

Fig. 5

Pivoting the Cushions

- 1) Hold the seat half by its handle located on its top corner.
- 2) Pivot the seat half either away from the transfer area or into position underneath the patient.

WARNING: To avoid injury, do not put fingers near the seat pivot when pivoting the cushion downwards.

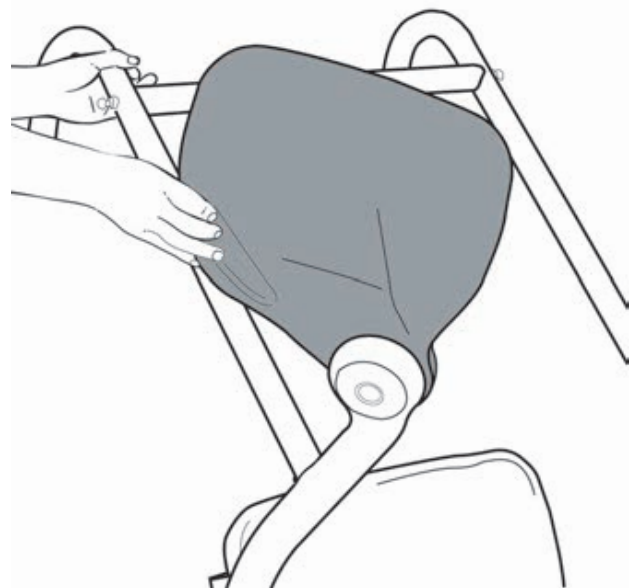

Fig. 6

How to Use the Sara Stedy

Opening and Closing the Legs

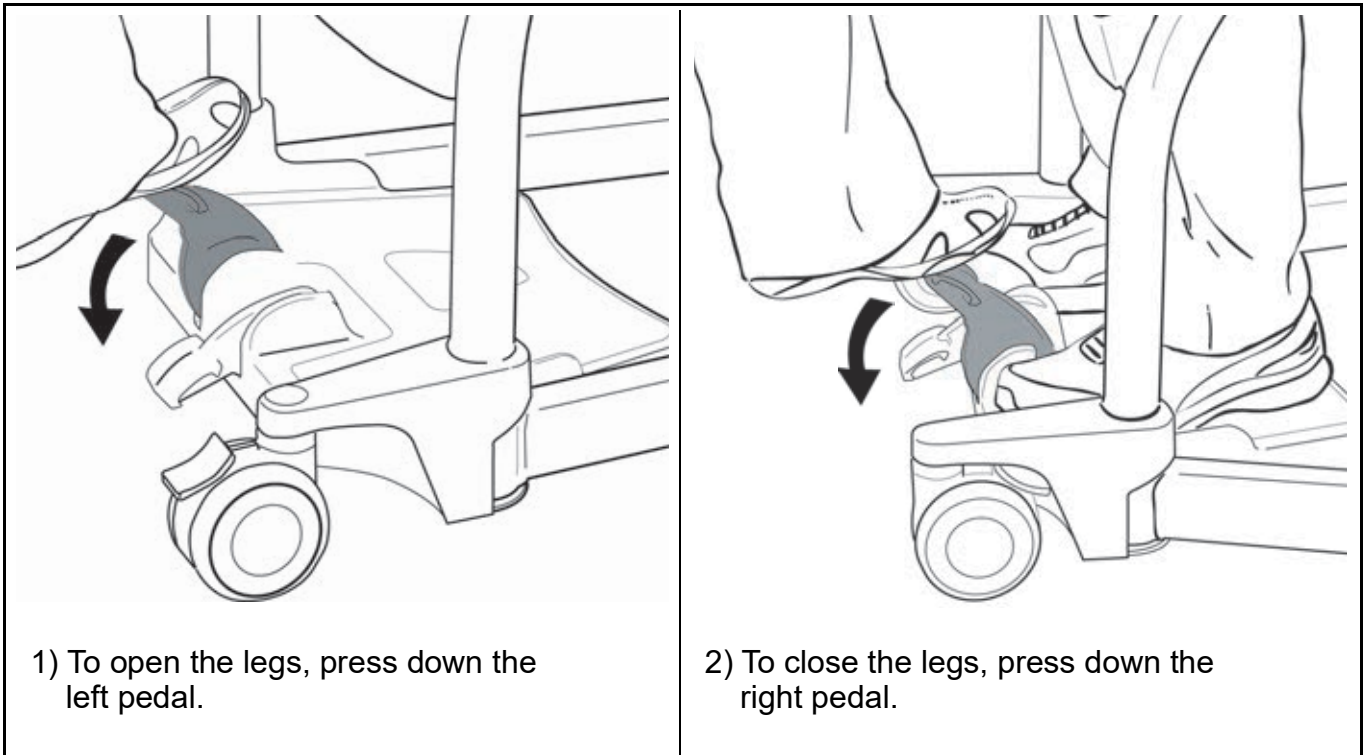

Fig. 7

Applying and Releasing the Brakes on the Rear Castors

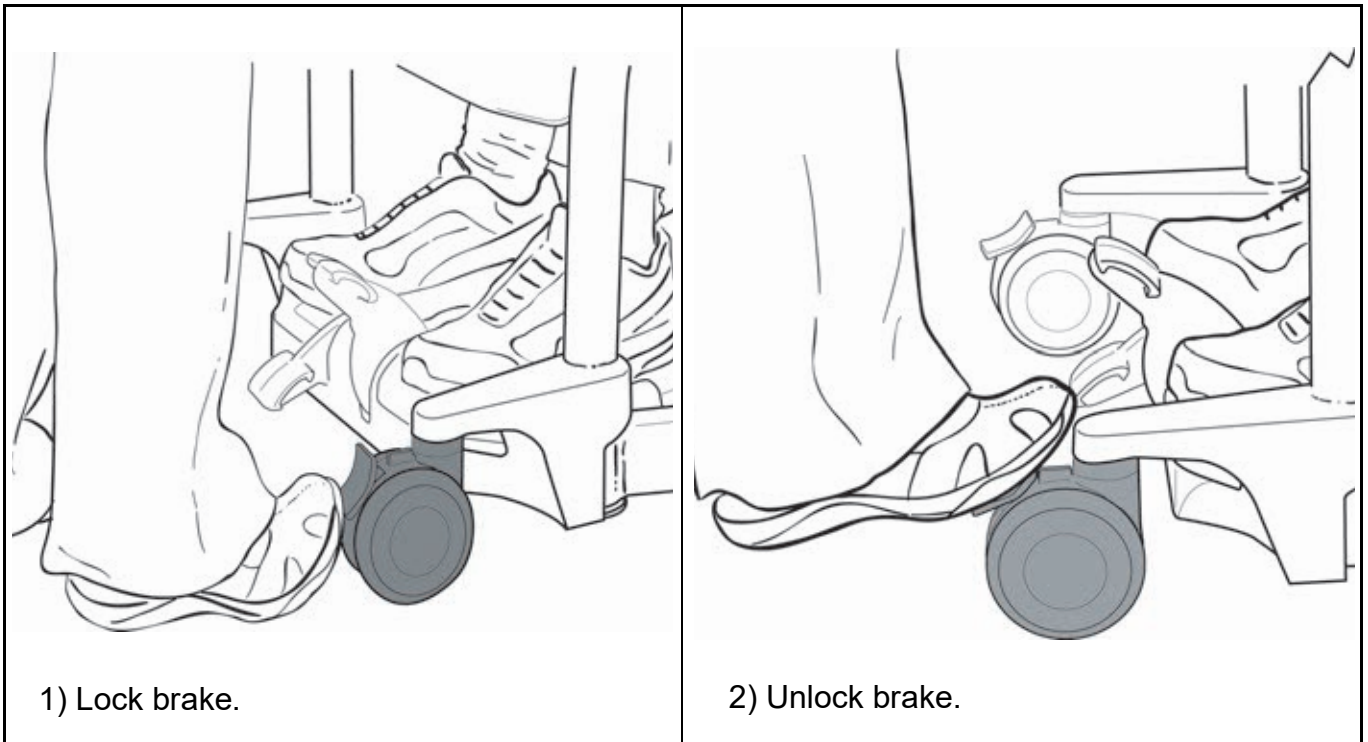

Fig. 8

How to Use the Sara Stedy

Approaching the Patient

Before Transferring the Patient

- Always inform the patient of what you are about to do.
- Ensure that you have the correct model and size of sling at hand if the patient has been assessed as requiring a sling.
- Before an attempt is made to move the patient, an assessment is performed by a qualified professional.

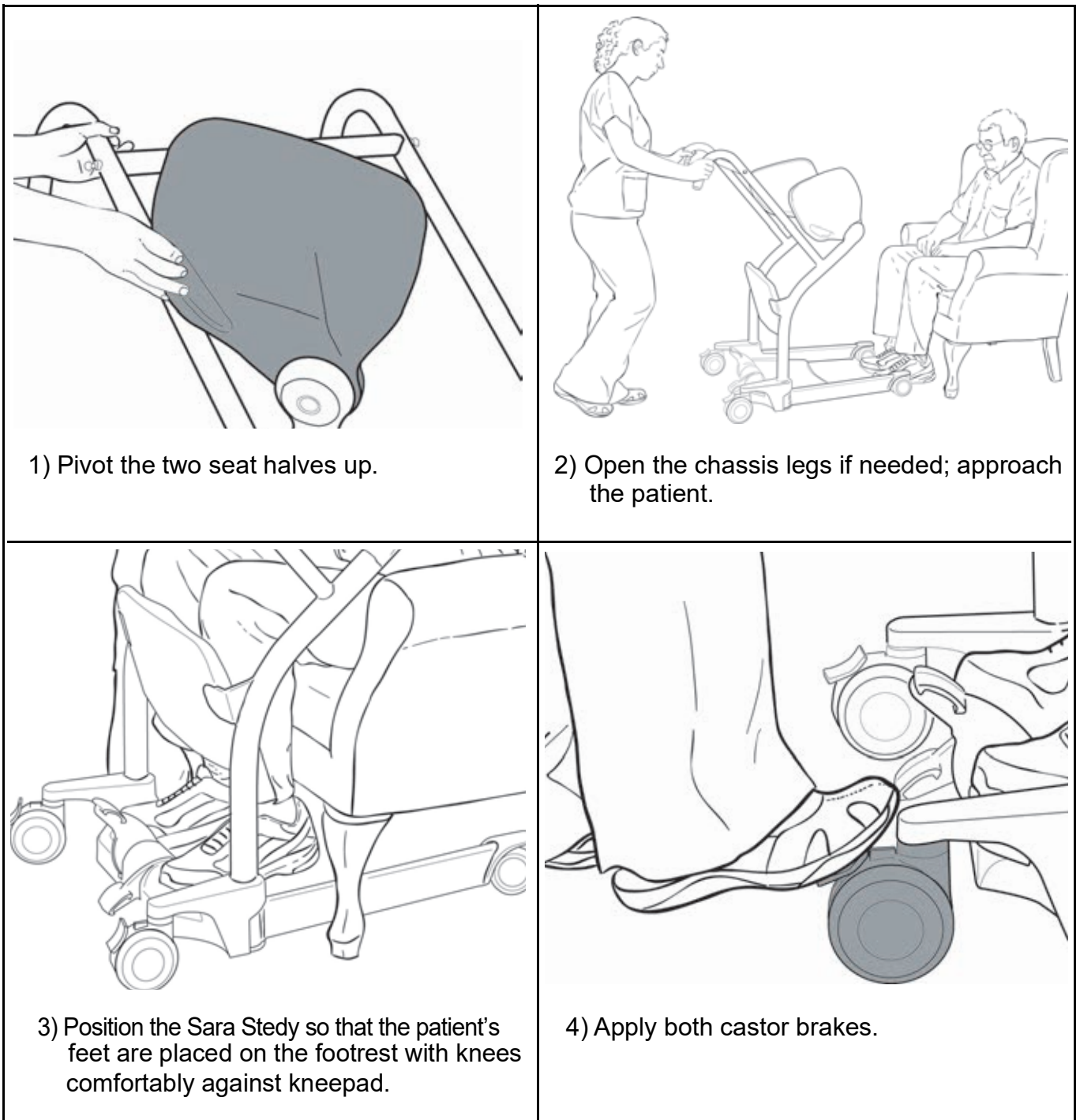

Fig. 9

How to Use the Sara Stedy

Transferring the Patient

Transferring the Patient from a Chair

- Help or encourage the patient to achieve the standing position.
- The patient's knees should stay in contact with the kneepad, and the patient should sit back on the seat halves during the transfer.

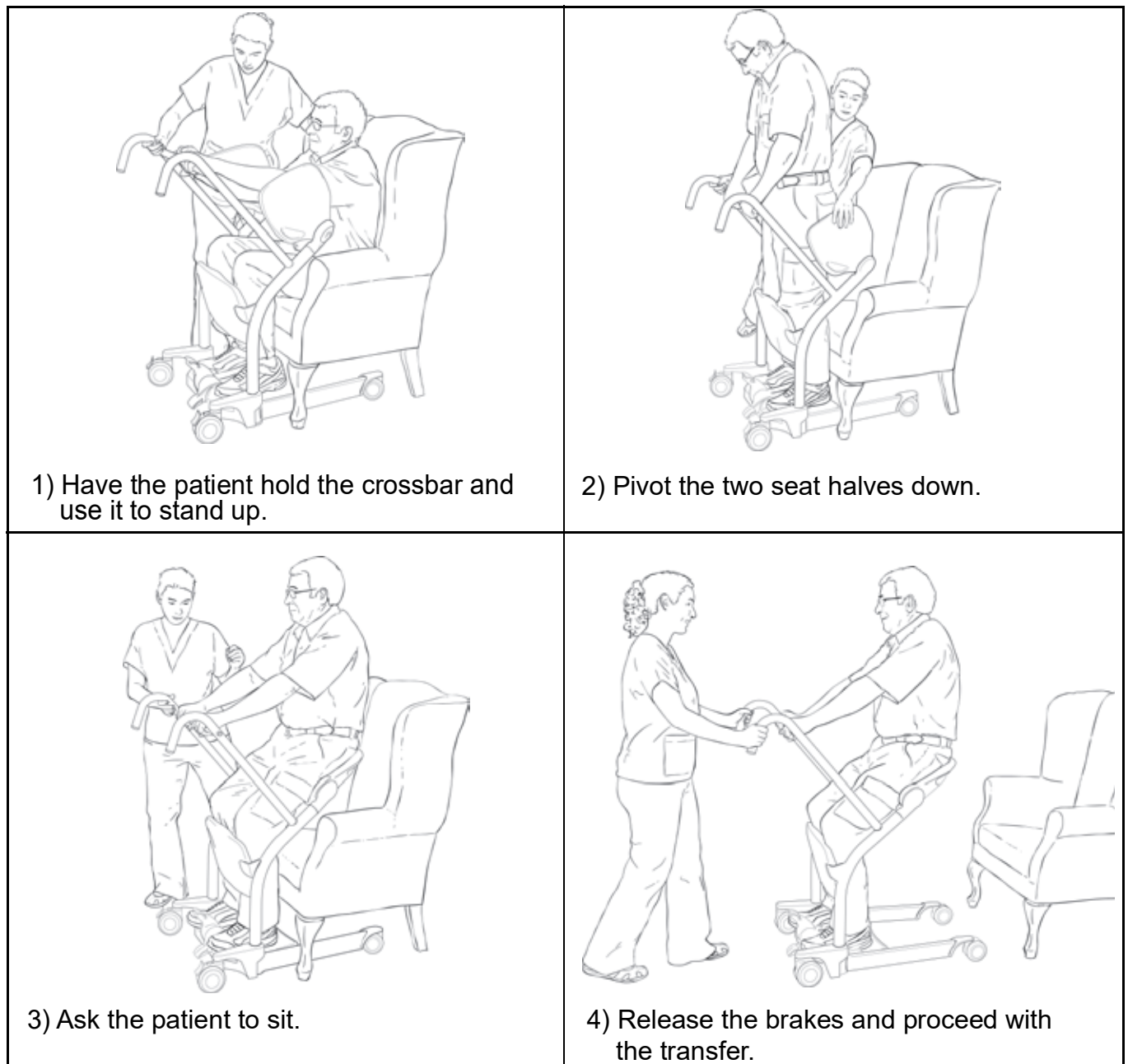

Fig. 10

How to Use the Sara Steady

Transferring the Patient to a Chair

- Help or encourage the patient to achieve the sitting position.
- The patient's knees should stay in contact with the kneepad, and the patient should sit back on the seat halves during the transfer.

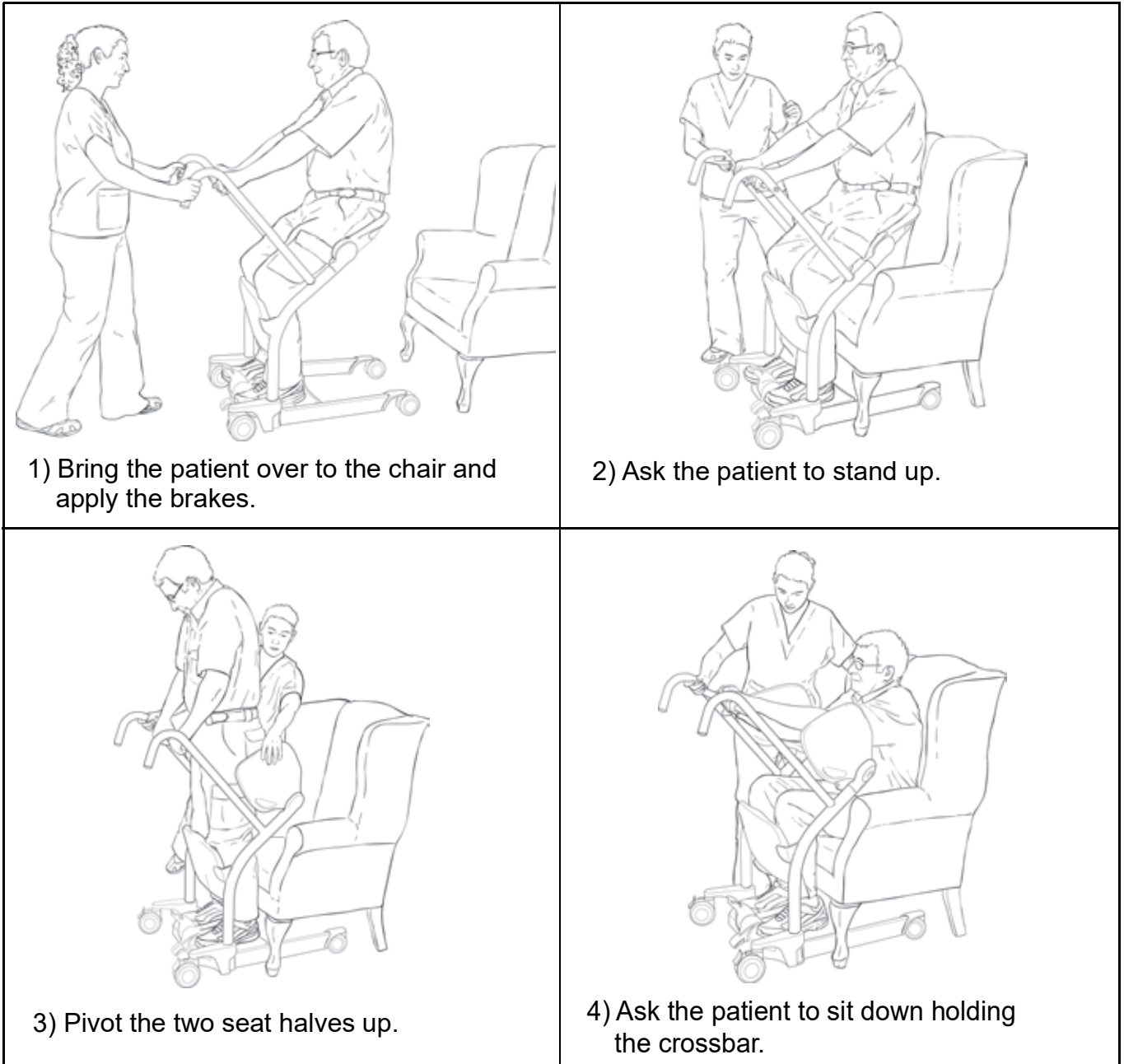

Fig. 11

How to Use the Sara Steady

Transferring the Patient from a Wheelchair

- Make sure to apply the wheelchair brakes.
- Help or encourage the patient to achieve the standing position.
- The patient's knees should stay in contact with the kneepad, and the patient should sit back on the seat halves during the transfer.



1) Have the patient hold the crossbar and use it to stand up.



2) Pivot the two seat halves down.



3) Ask the patient to sit.



4) Release the brakes and proceed with the transfer.

Fig. 12

How to Use the Sara Stedy

Transferring the Patient to a Wheelchair

- Make sure to apply the wheelchair brakes.
- Help or encourage the patient to achieve the sitting position.
- The patient's knees should stay in contact with the kneepad, and the patient should sit back on the seat halves during the transfer.

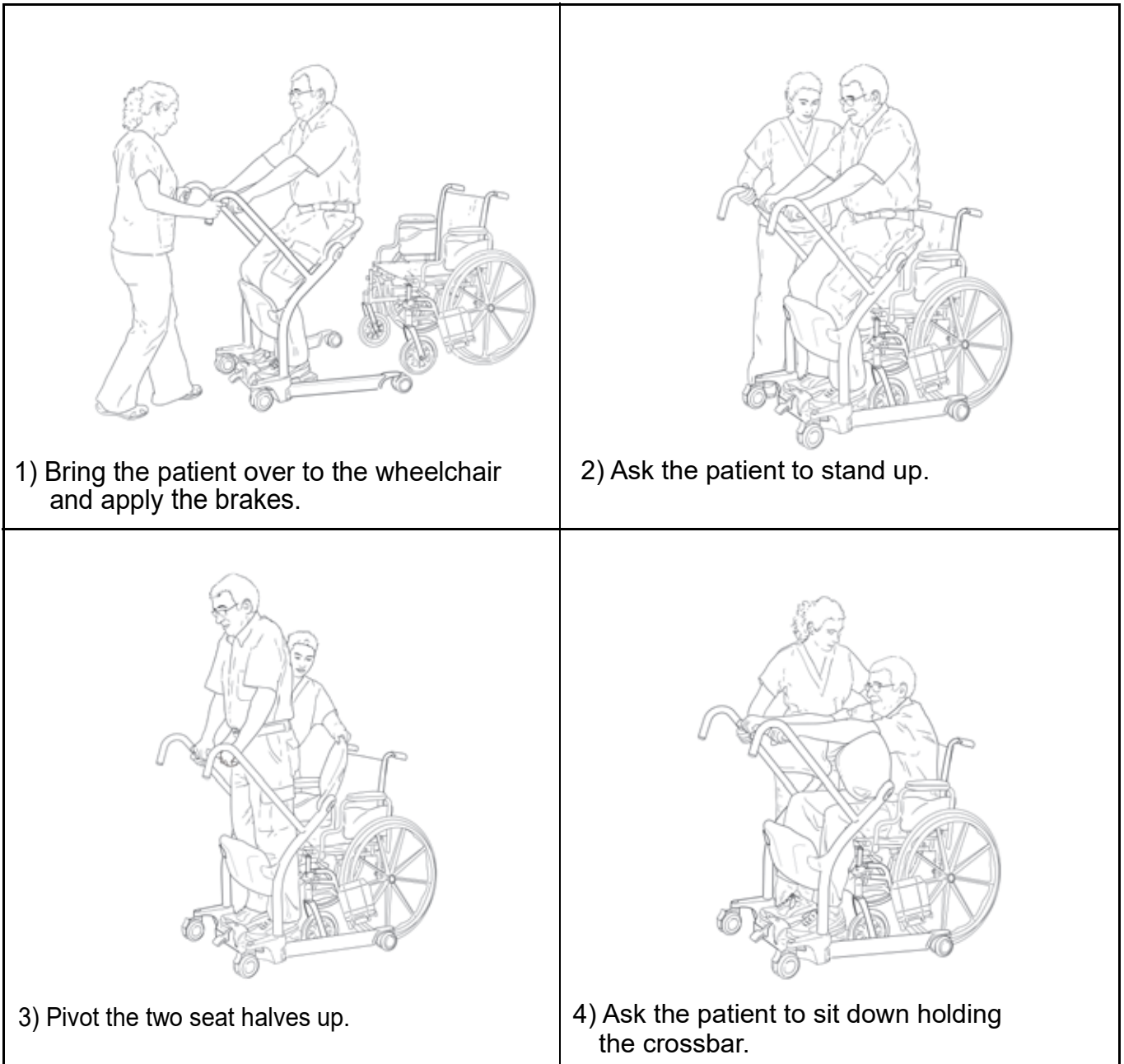

Fig. 13

How to Use the Sara Steady

Transferring the Patient from a Bed

- Help or encourage the patient to achieve the standing position.
- The patient's knees should stay in contact with the kneepad, and the patient should sit back on the seat halves during the transfer.

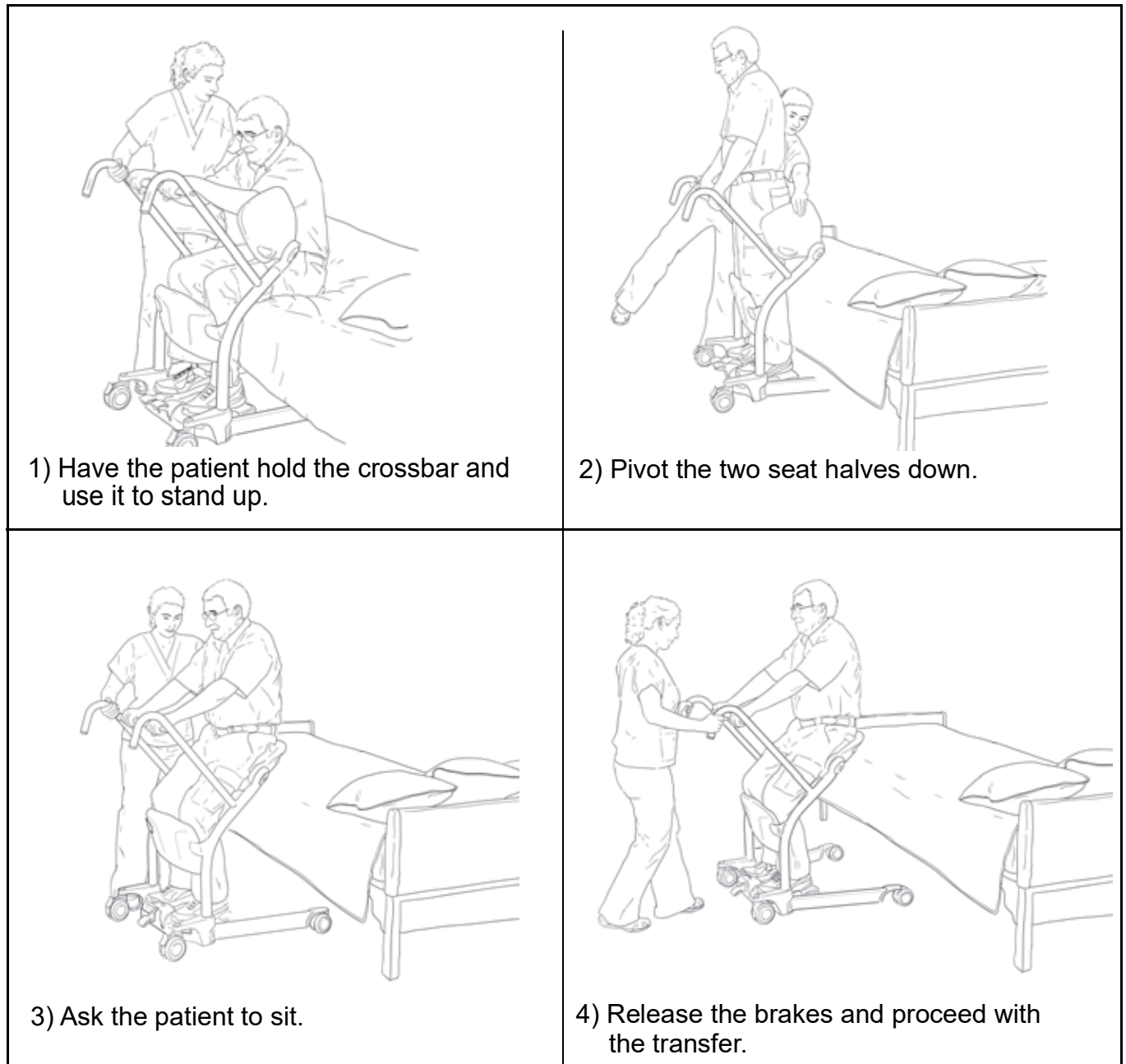

Fig. 14

How to Use the Sara Stedy

Transferring the Patient to a Bed

- Help or encourage the patient to achieve the sitting position.
- The patient's knees should stay in contact with the kneepad, and the patient should sit back on the seat halves during the transfer.

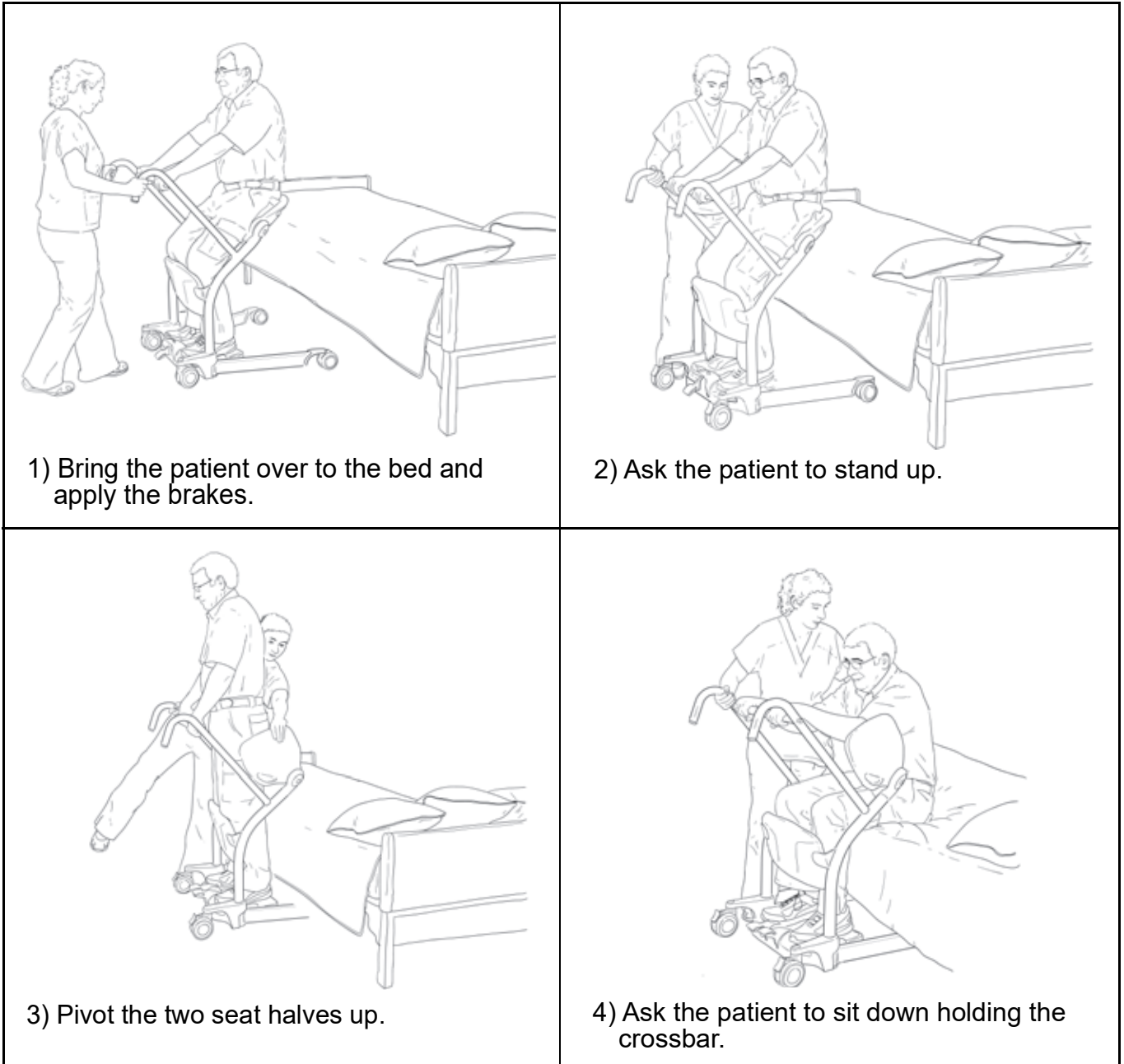

Fig. 15

How to Use the Sara Steady

Transferring the Patient from a Toilet

- Help or encourage the patient to achieve the standing position.
- The patient's knees should stay in contact with the kneepad, and the patient should sit back on the seat halves during the transfer.

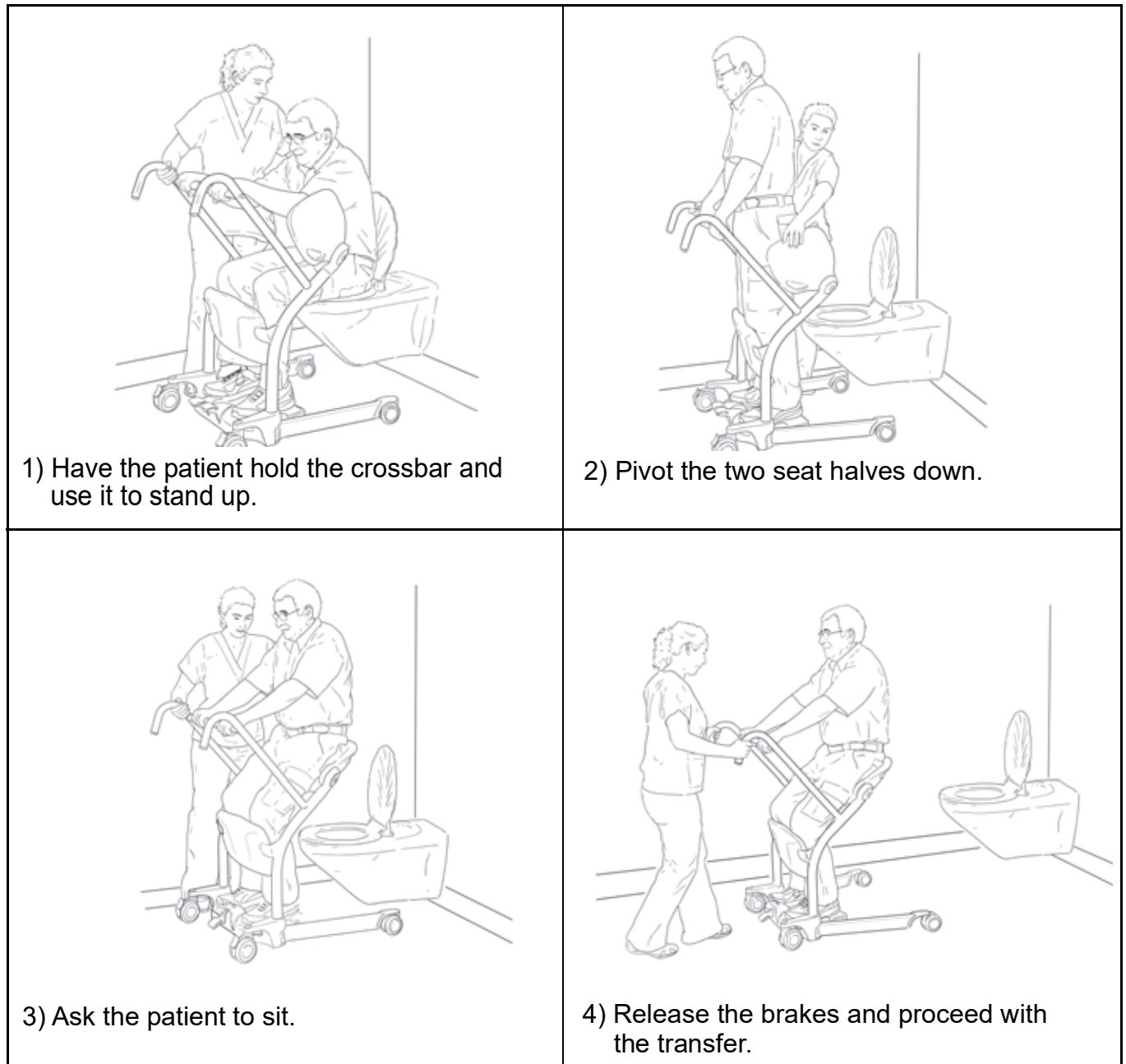

Fig. 16

How to Use the Sara Steady

Transferring the Patient to a Toilet

- Help or encourage the patient to achieve the sitting position.
- The patient's knees should stay in contact with the kneepad, and the patient should sit back on the seat halves during the transfer.

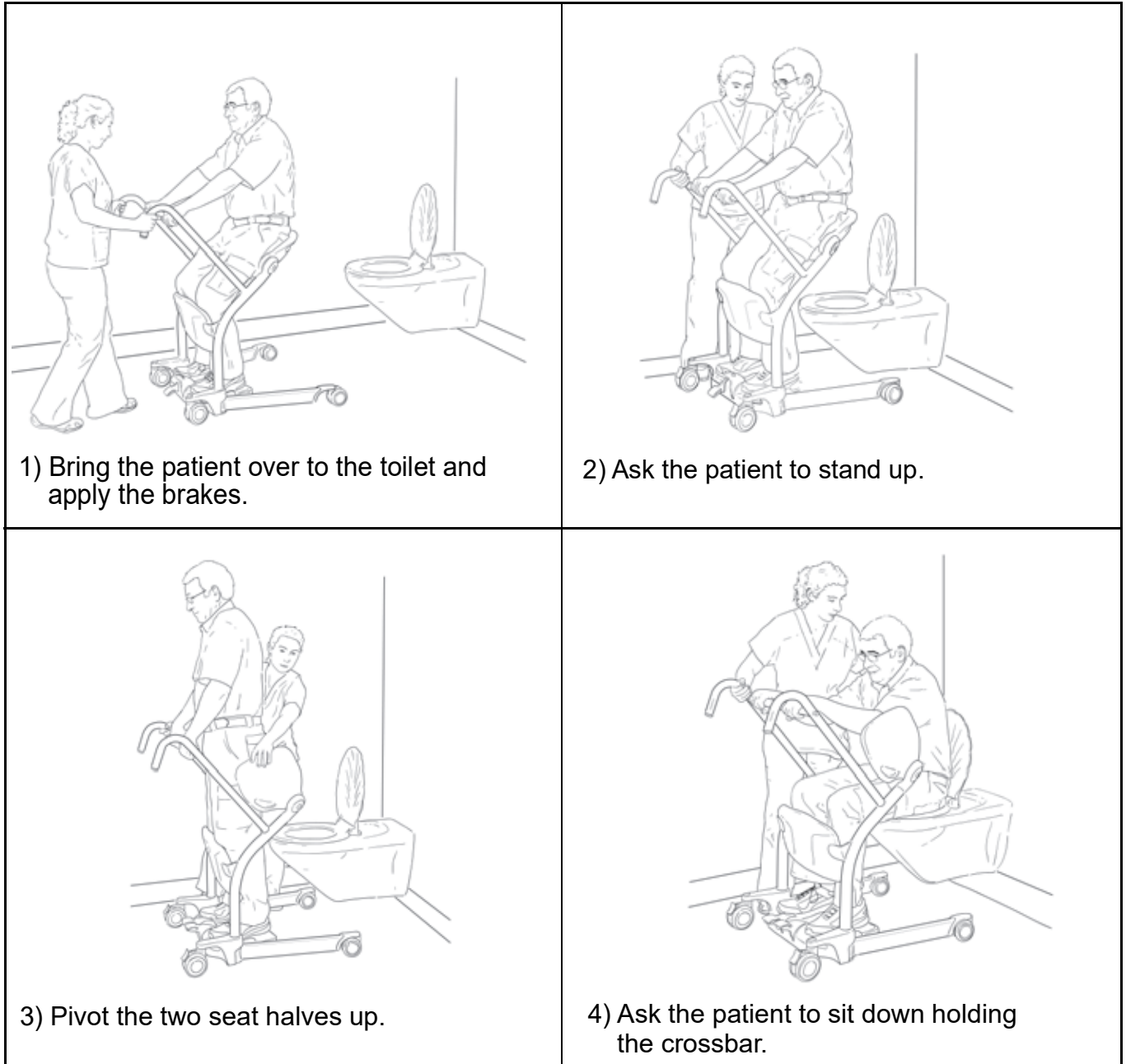

Fig. 17

Transferring the Patient at the Toilet

- Once the patient is in place, apply the castor brakes and ask the patient to stand.
- Remove the patient's clothing as necessary, then pivot the seat halves upwards to allow the patient to lower herself/himself onto the toilet seat. The Sara Steady can thus function as a support frame, improving the patient's confidence.

How to Use the Sara Steady

Back Support Strap

Using the Back Support Strap

Use of this accessory is recommended where the patient would benefit from extra confidence and support. To use the back support strap:

- Position the strap at around 50 mm (2") above the waistline.
- Be careful not to pull the patient forward too much when connecting the support strap.

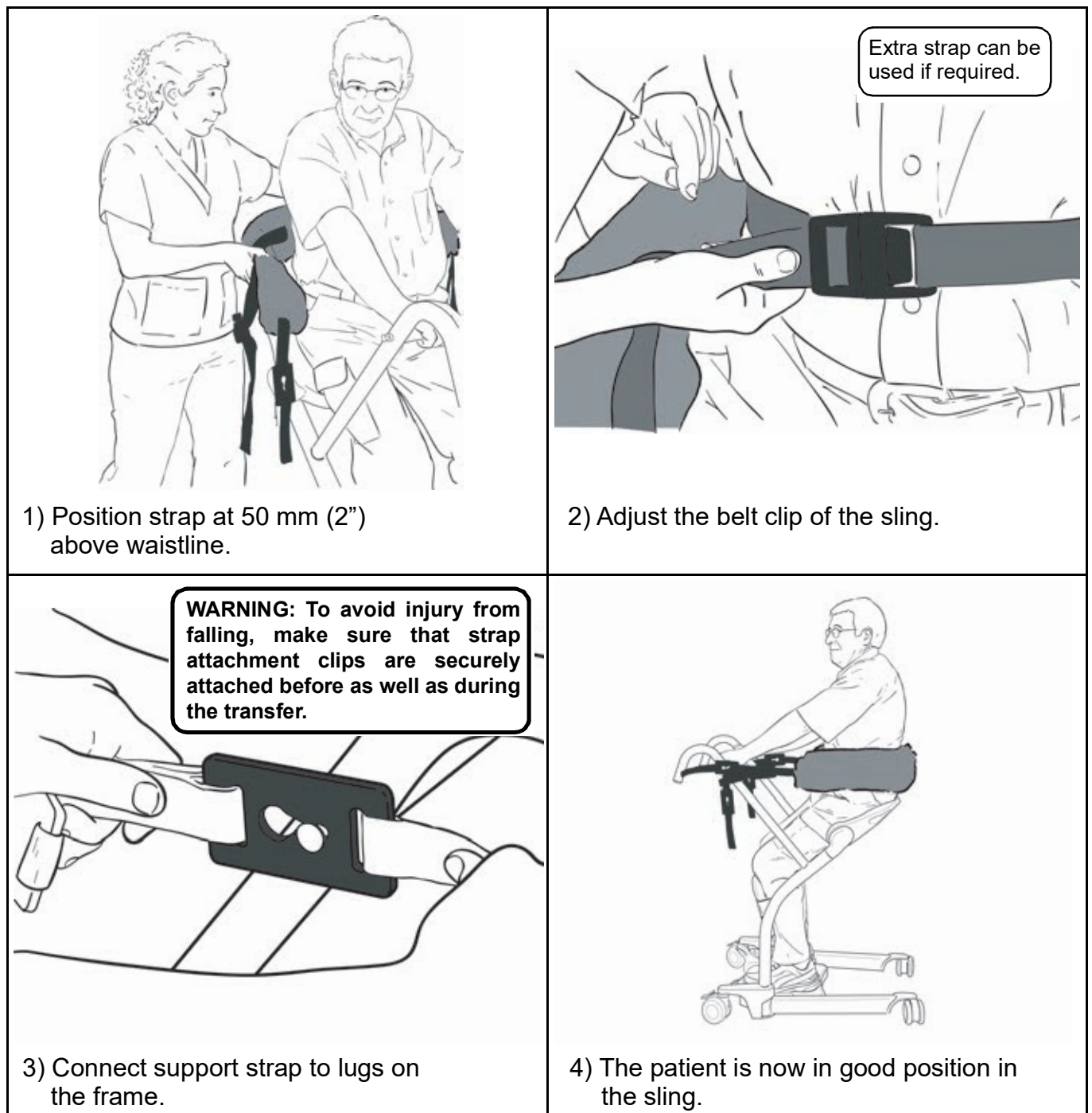

Fig. 18

How to Use the Sara Steady

Kneepad cushion (optional)

Use of this accessory is recommended where the patient would benefit from additional padding.

Installing the kneepad cushion

- Snugly fit the kneepad cushion over the kneepad with the padded surface facing the seat halves, the Arjo logo right side up and the strap behind the kneepad.

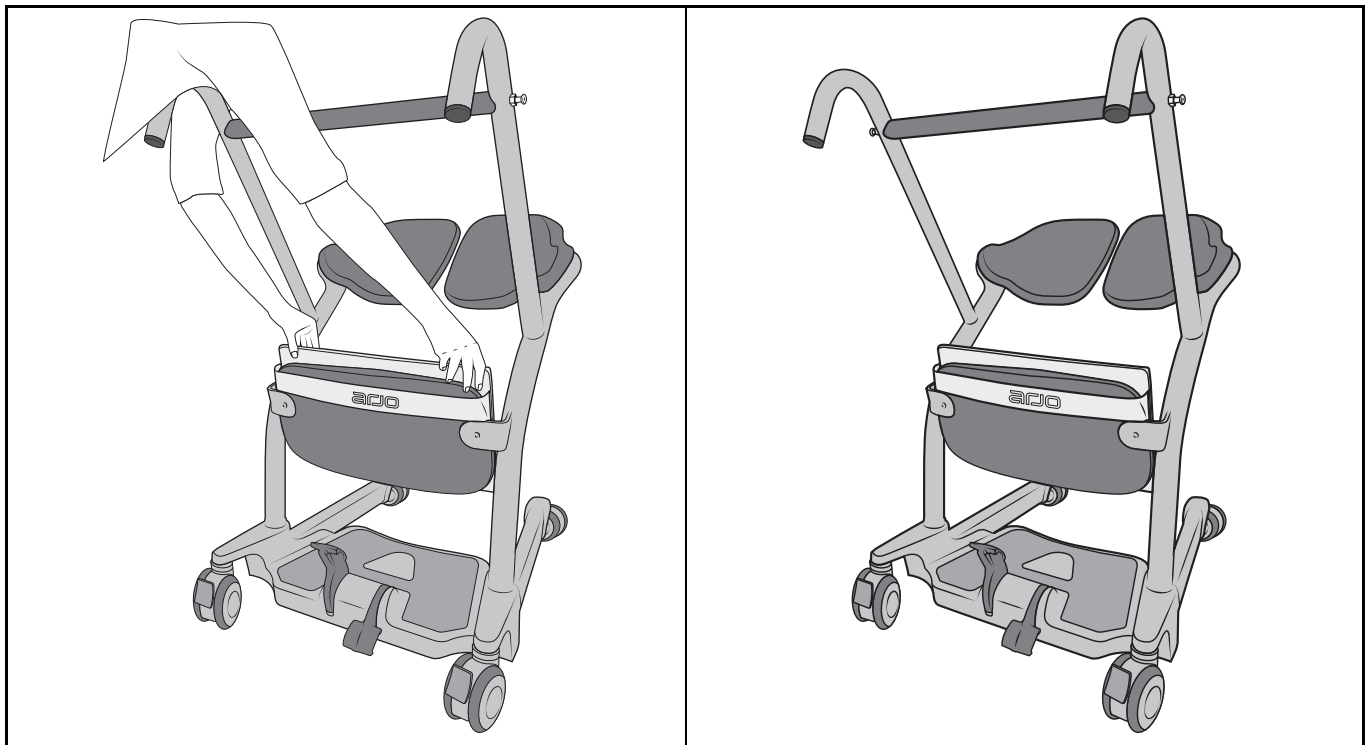

Fig. 19

Removal of the kneepad cushion

- Pull the cushion upwards to release it from the kneepad.

Care and Maintenance

Preventive Maintenance Schedule

The equipment is subjected to wear and tear, and the following maintenance instructions must be acted upon when specified to ensure that the equipment remains within its original manufacturing specifications. Care and maintenance must be carried out in accordance with the preventive maintenance schedule below.

Customer obligations must be carried out by qualified personnel in accordance with the instructions in this manual.

WARNING: The maintenance described in the following checklist is the minimum that the manufacturer recommends. In some cases more frequent inspections should be carried out. Continuing to use this equipment without conducting regular inspections or when a fault is found will seriously compromise the safety of the user and of the patient. Local regulations and standards may be higher than those of the manufacturer. Service and preventive maintenance can be arranged with the manufacturer. Preventive maintenance specified in this manual can prevent accidents and reduce repair costs.

WARNING: Safety related maintenance and authorized service must be carried out by qualified personnel, fully trained in servicing procedures by Arjo, and equipped with correct tools. Failure to meet these requirements could result in personal injuries and/or unsafe equipment.

User Inspections

Action/check	Before every use	Every week	Every year
Transport device			
Carry out a visual inspection of all external parts. All functions must be tested for correct operation to ensure that no damage has occurred during previous use.	X		
Inspect for missing hardware or broken parts.	X		X
Inspect the sling lugs on the lift for damage or cracks.			X
Ensure that the castors are firmly secured to the chassis.		X	
Make sure all castors rotate freely and the two rear brakes lock.	X		
Check front and rear castors regularly for hair and debris; clean when necessary.		X	

Care and Maintenance

Action/check	Before every use	Every week	Every year
Examine all exposed parts, especially where there is personal contact with the patient's body. Make sure no cracks or sharp edges have developed that could cause patient or user injury or have become unhygienic. Replace where necessary and decontaminate.		X	
Check the opening of the legs. The mechanism must open freely without using excessive force.		X	
Make sure that the anti-skid material is well glued to the chassis. Replace if needed.			X
Check leg opening mechanism under lift base. Make sure that mobile parts don't have excessive loose and are free of hair and debris.			X
Sling and hardware			
Check all sling attachments for sign of wear.	X		
Inspect sling material for wear or deterioration.	X		
Inspect sling straps for wear.	X		
Inspect for any defects or loose threads in the "stitched areas".	X		

NOTE: If the product does not work as intended, immediately contact your local Arjo representative for support.

Care and Maintenance

Cleaning and Disinfection

WARNING: To prevent cross-contamination, always follow the disinfection instructions in this IFU.

To clean the Sara Stedy:

- 1) Use a cloth soaked with water to remove excessive residues.
- 2) Use a damp cloth with warm water mixed with a cleaning fluid.
- 3) Scrub the equipment from top to bottom to remove any deposit.
- 4) Use a clean damp cloth with clear water to wipe off all spots of cleaning fluids.
- 5) Wipe clean with dry cloth.

To disinfect the Sara Stedy, clean the equipment first, then wipe it using a solution containing one of the compatible disinfectants below:

Disinfectant Agents	Sara Stedy	Pivoting Seat Halves (seat pads)	Kneepad	Kneepad cushion
Quaternary Ammonium $\leq 0.28\%$ (2,800 ppm)	X	X	X	X
Isopropyl Alcohol $\leq 70\%$	X	X	X	X
Phenolic $\leq 1.56\%$ (15,600 ppm)	X	X	X	X
Peracetic Acid $\leq 0.25\%$ (2,500 ppm)	X	X	X	X
Bleach $\leq 1\%$ (10,000 ppm)	X	X*	X*	X
Hydrogen Peroxide $\leq 1.5\%$	X	X	X	X

* Discolouration may occur over time if this agent is used.

Disinfection methods should comply with the local or national guidelines (Decontamination of Medical Devices), depending on the Healthcare Facility or country of use.

If uncertain, consult your local Infection Control specialist.

Sling Inspection and Care

See the documentation that comes with your sling.

Care and Maintenance

Annual Inspection

The Sara Stedy and its accessories must be inspected annually by a qualified technician.

WARNING: To avoid injury and/or unsafe product, the maintenance activities must be carried out at the correct frequency by qualified personnel using correct tools, parts and knowledge of procedure. Qualified personnel must have documented training in maintenance of this device.

WARNING: To avoid eye and skin damage, always use protective glasses and gloves. If contact occurs, rinse with plenty of water. If eyes or skin become irritated, contact physician. Always read the IFU and material safety data sheet of the disinfectant.



Troubleshooting

Lift Trouble	Resolution
Poor maneuverability	<ul style="list-style-type: none">• Check castor for any damage or wear.• Remove hair and debris from castor.
Legs do not open or close	<ul style="list-style-type: none">• Check legs opening mechanism for damage. Call Arjo for replacement if needed.
Legs difficult to open or close	<ul style="list-style-type: none">• Check legs opening mechanism for damage. Call Arjo for replacement if needed.• Legs opening mechanism need lubrication. Call Arjo for service.
Noise during opening	<ul style="list-style-type: none">• Legs opening mechanism need lubrication. Call Arjo for service.
Seat difficult to open or close	<ul style="list-style-type: none">• Check for debris or hair in the seat pivot. Clean if needed.

Labels on the Sara Steady

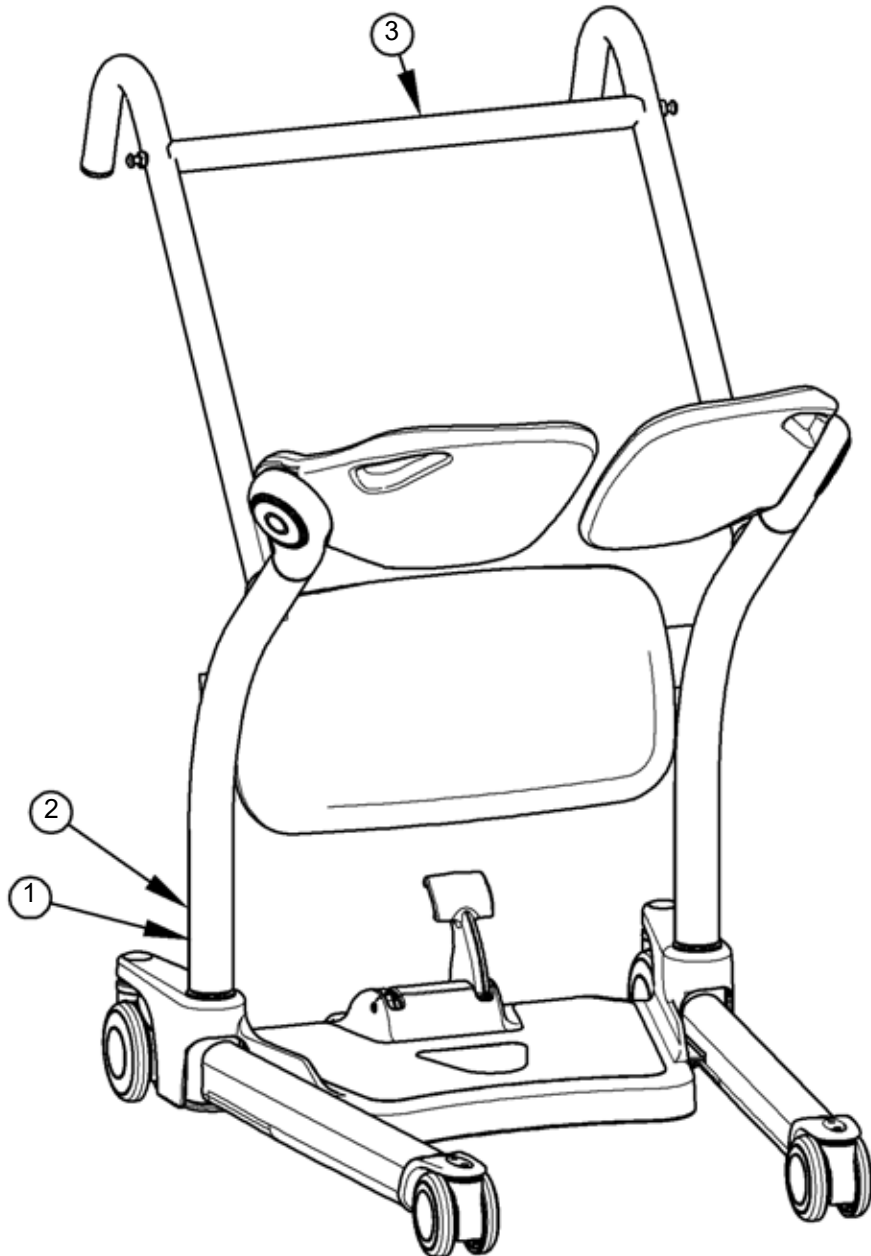

- 1) Serial number label
- 2) Product label
- 3) Product name

Fig. 20

Technical Specifications

PRODUCT INFORMATION	Sara Stedy and Sara Stedy Compact
Weight, complete Sara Stedy:	28.6kg (63.1lb)
Weight, complete Sara Stedy Compact:	28.0kg (61.7lb)
Lifting capacity	182kg (400lb)
Turning radius	1168 mm (46 in)
Minimum door requirement	630 mm (24.80 in)
Pedal operating force	< 300 N
OPERATION AND STORAGE CONDITIONS	
Ambient temperature range (lift)	Operation: 10 ° to 40 °C (+50 to +104 °F), Storage: -40 ° to 70 °C (-40 to 158 °F)
Relative humidity range	Operation: 30 to 95 %, Storage: 0 to 90% non-condensing
Atmospheric pressure range	Operation: 700 hPa to 1060 hPa, Storage: 500 hPa to 1060 hPa
SAFE DISPOSAL at END of LIFE	
Package	Wood and corrugated cardboard, recyclable.
Product	Components that are primarily be made up of different kinds of metal (containing more than 90% metal by weight) for example sling bars, rails, upright supports, etc., should be recycled as metals.
Slings	Slings including stiffeners/stabilizers, padding material, any other textiles or polymers or plastic materials etc. should be sorted as combustible waste.

Technical Specifications

Lift Dimensions Sara Steady

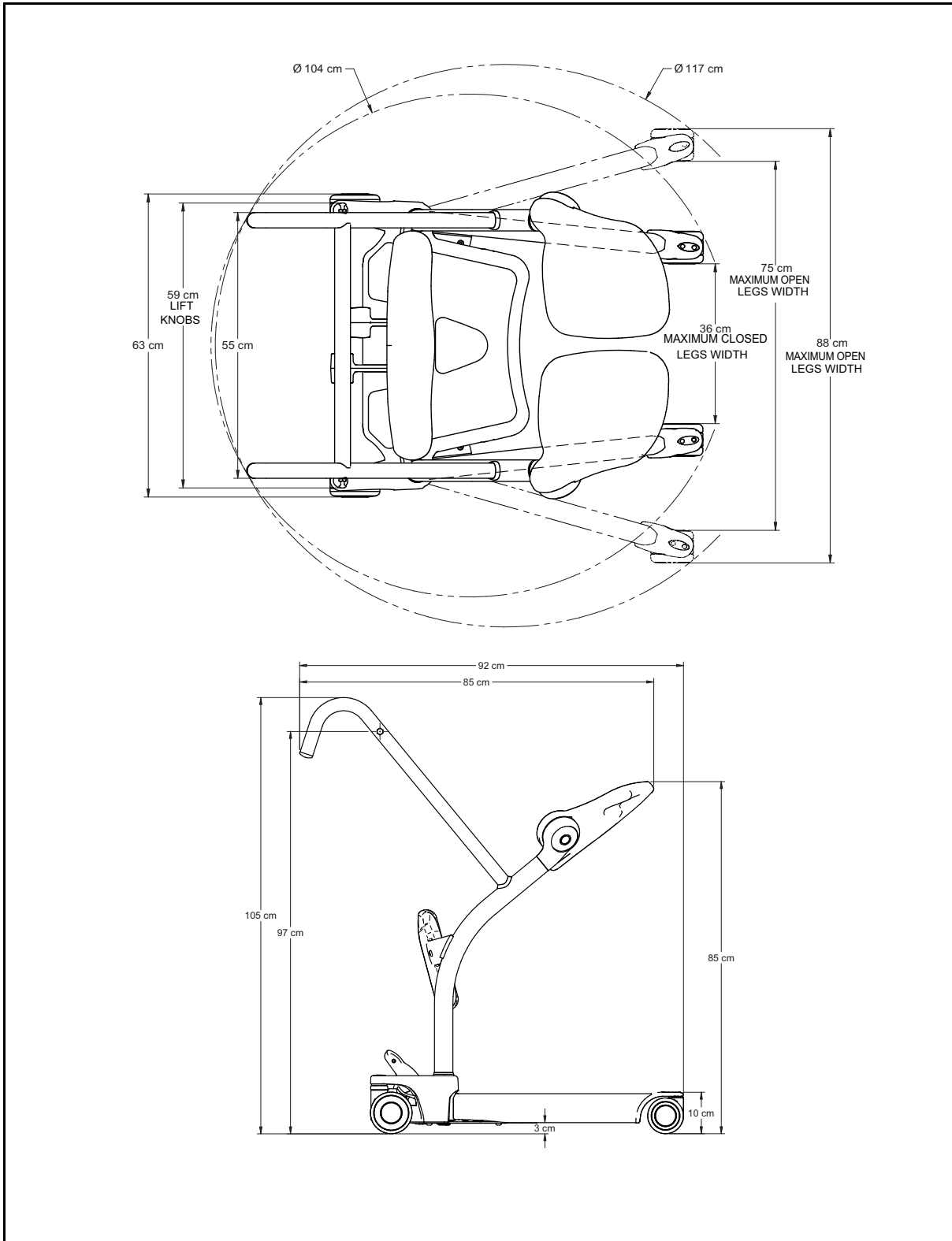

Fig. 21

Technical Specifications

Lift Dimensions Sara Steady Compact

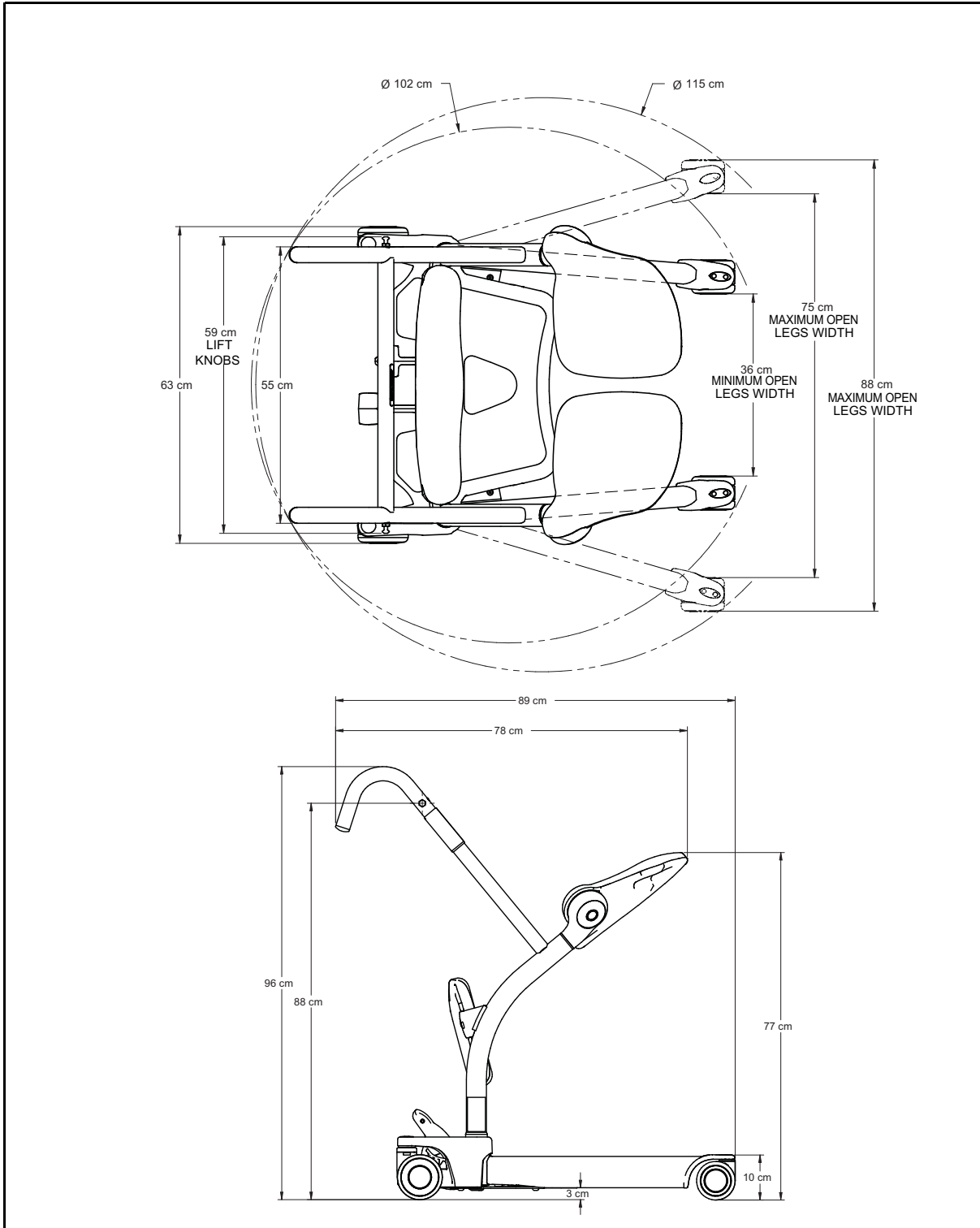

Fig. 22

Intentionally left blank

Intentionally left blank

Intentionally left blank

AUSTRALIA
Arjo Australia
Building B, Level 3
11 Talavera Road
Macquarie Park, NSW, 2113,
Australia
Phone: 1800 072 040

BELGIQUE / BELGIË
Arjo Belgium
Evenbroekveld 16
9420 Erpe-Mere
Phone: +32 (0) 53 60 73 80
Fax: +32 (0) 53 60 73 81
E-mail: info.belgium@arjo.com

BRASIL
Arjo Brasil Equipamentos Médicos Ltda
Rua Marina Ciufulli Zanfelice, 329 PB02
Galpão - Lapa
São Paulo – SP – Brasil
CEP: 05040-000
Phone: 55-11-3588-5088
E-mail: vendas.latam@arjo.com
E-mail: servicios.latam@arjo.com

CANADA
Arjo Canada Inc.
90 Matheson Boulevard West
Suite 350
CA-MISSISSAUGA, ON, L5R 3R3
Tel/Tél: +1 (905) 238-7880
Free: +1 (800) 665-4831
Fax: +1 (905) 238-7881
E-mail: info.canada@arjo.com

ČESKÁ REPUBLIKA
Arjo Czech Republic s.r.o.
Na Strži 1702/65
140 00 Praha
Czech Republic
Phone No: +420225092307
E-mail: info.cz@arjo.com

DANMARK
Arjo A/S
Vassingerødvej 52
DK-3540 LYNGE
Tel: +45 49 13 84 86
Fax: +45 49 13 84 87
E-mail: dk_kundeservice@arjo.com

DEUTSCHLAND
Arjo GmbH
Peter-Sander-Strasse 10
DE-55252 MAINZ-KASTEL
Tel: +49 (0) 6134 186 0
Fax: +49 (0) 6134 186 160
E-mail: info-de@arjo.com

ESPAÑA
ARJO IBERIA S.L.
Poligono Can Salvatella
c/ Cabanyes 1-7
08210 Barberà del Valles
Barcelona - Spain
Telefono 1: +34 900 921 850
Telefono 2: +34 931 315 999

FRANCE
Arjo SAS
2 Avenue Alcide de Gasperi
CS 70133
FR-59436 RONCQ CEDEX
Tél: +33 (0) 3 20 28 13 13
Fax: +33 (0) 3 20 28 13 14
E-mail: info.france@arjo.com

HONG KONG
Arjo Hong Kong Limited
Room 411-414, 4/F, Manhattan Centre,
8 Kwai Cheong Road, Kwai Chung, N.T.,
HONG KONG
Tel: +852 2960 7600
Fax: +852 2960 1711

ITALIA
Arjo Italia S.p.A.
Via Giacomo Peroni 400-402
IT-00131 ROMA
Tel: +39 (0) 6 87426211
Fax: +39 (0) 6 87426222
E-mail: Italy.promo@arjo.com

MIDDLE EAST
Arjo Middle East FZ-LLC
Office 908, 9th Floor,
HQ Building, North Tower,
Dubai Science Park,
Al Barsha South
P.O. Box 11488, Dubai,
United Arab Emirates
Direct +971 487 48053
Fax +971 487 48072
Email: Info.ME@arjo.com

NEDERLAND
Arjo Nederland BV
Biezenwei 21
4004 MB TIEL
Postbus 6116
4000 HC TIEL
Tel: +31 (0) 344 64 08 00
Fax: +31 (0) 344 64 08 85
E-mail: info.nl@arjo.com

NEW ZEALAND
Arjo Ltd
34 Vestey Drive
Mount Wellington
NZ-AUCKLAND 1060
Tel: +64 (0) 9 573 5344
Free Call: 0800 000 151
Fax: +64 (0) 9 573 5384
E-mail: nz.info@Arjo.com

NORGE
Arjo Norway AS
Olaf Helsets vei 5
N-0694 OSLO
Tel: +47 22 08 00 50
Faks: +47 22 08 00 51
E-mail: no.kundeservice@arjo.com

ÖSTERREICH
Arjo Austria GmbH
Lemböckgasse 49 / Stiege A / 4.OG
A-1230 Wien
Tel: +43 1 8 66 56
Fax: +43 1 866 56 7000

POLSKA
Arjo Polska Sp. z o.o.
ul. Ks Piotra Wawrzyniaka 2
PL-62-052 KOMORNIKI (Poznań)
Tel: +48 61 662 15 50
Fax: +48 61 662 15 90
E-mail: arjo@arjo.com

PORTUGAL
Arjo em Portugal
MAQUET Portugal, Lda.
(Distribuidor Exclusivo)
Rua Poeta Bocage n.º 2 - 2G
PT-1600-233 Lisboa
Tel: +351 214 189 815
Fax: +351 214 177 413
E-mail: Portugal@arjo.com

SUISSE / SCHWEIZ
Arjo Switzerland AG
Fabrikstrasse 8
Postfach
CH-4614 HÄGENDORF
Tél/Tel: +41 (0) 61 337 97 77
Fax: +41 (0) 61 311 97 42

SUOMI
Arjo Scandinavia AB
Riihitontuntie 7 C
02200 Espoo
Finland
Puh: +358 9 6824 1260
E-mail: Asiakaspalvelu.finland@arjo.com

SVERIGE
Arjo International HQ
Hans Michelsensgatan 10
SE-211 20 MALMÖ
Tel: +46 (0) 10 494 7760
Fax: +46 (0) 10 494 7761
E-mail: kundservice@arjo.com

UNITED KINGDOM
Arjo UK and Ireland
Houghton Hall Park
Houghton Regis
UK-DUNSTABLE LU5 5XF
Tel: +44 (0) 1582 745 700
Fax: +44 (0) 1582 745 745
E-mail: sales.admin@arjo.com

USA
Arjo Inc.
2349 W Lake Street Suite 250
US-Addison, IL 60101
Tel: +1 (630) 307-2756
Free: +1 (800) 323-1245
Fax: +1 (630) 307 6195
E-mail: us.info@arjo.com

JAPAN
Arjo Japan K.K.
東京都港区虎ノ門三丁目7番8号
ランドミック第2 虎ノ門ビル9階
Tel: +81 (0)3-6435-6401
Fax: +81 (0)3-6435-6402
E-mail: info.japan@arjo.com

At Arjo, we believe that empowering movement within healthcare environments is essential to quality care. Our products and solutions are designed to promote a safe and dignified experience through patient handling, medical beds, personal hygiene, disinfection, diagnostics, and the prevention of pressure injuries and venous thromboembolism. With over 6500 people worldwide and 65 years caring for patients and healthcare professionals, we are committed to driving healthier outcomes for people facing mobility challenges.



ArjoHuntleigh AB
Hans Michelsensgatan 10
211 20 Malmö, Sweden
www.arjo.com

arjo



001-12325-EN

